

VESTING TENTATIVE TRACT MAP NO. 74577

FOR LOT CONSOLIDATION AND ALLEY MERGER PURPOSES

IN THE CITY OF LOS ANGELES, COUNTY OF LOS ANGELES, STATE OF CALIFORNIA, BEING A MERGER OF LOT 1, OF TRACT NO. 24637, IN THE CITY OF LOS ANGELES, COUNTY OF LOS ANGELES, STATE OF CALIFORNIA, AS PER MAP RECORDED IN BOOK 665, PAGES 15 AND 16 OF MAPS, LOTS 246, AND LOTS 268 TO LOT 273, INCLUSIVE, AND THE MERGER OF A PORTION OF AN ALLEY AS SHOWN ON TRACT NO. 9275, IN THE CITY OF LOS ANGELES, COUNTY OF LOS ANGELES, STATE OF CALIFORNIA, AS PER MAP RECORDED IN BOOK 149, PAGES 15 TO 17 INCLUSIVE, OF MAPS, BOTH IN THE OFFICE OF THE COUNTY RECORDER OF SAID COUNTY.

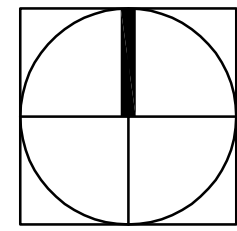
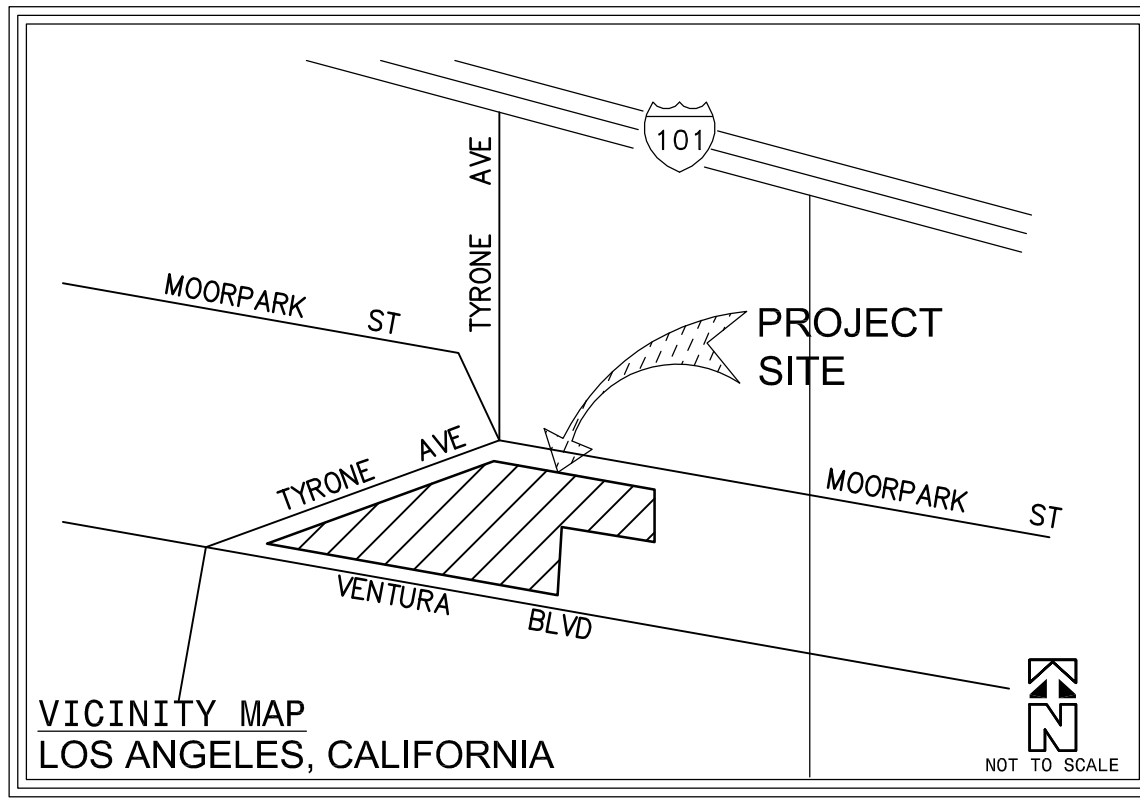

0 15 30 60 90 120
SCALE: 1 INCH = 30 FEET

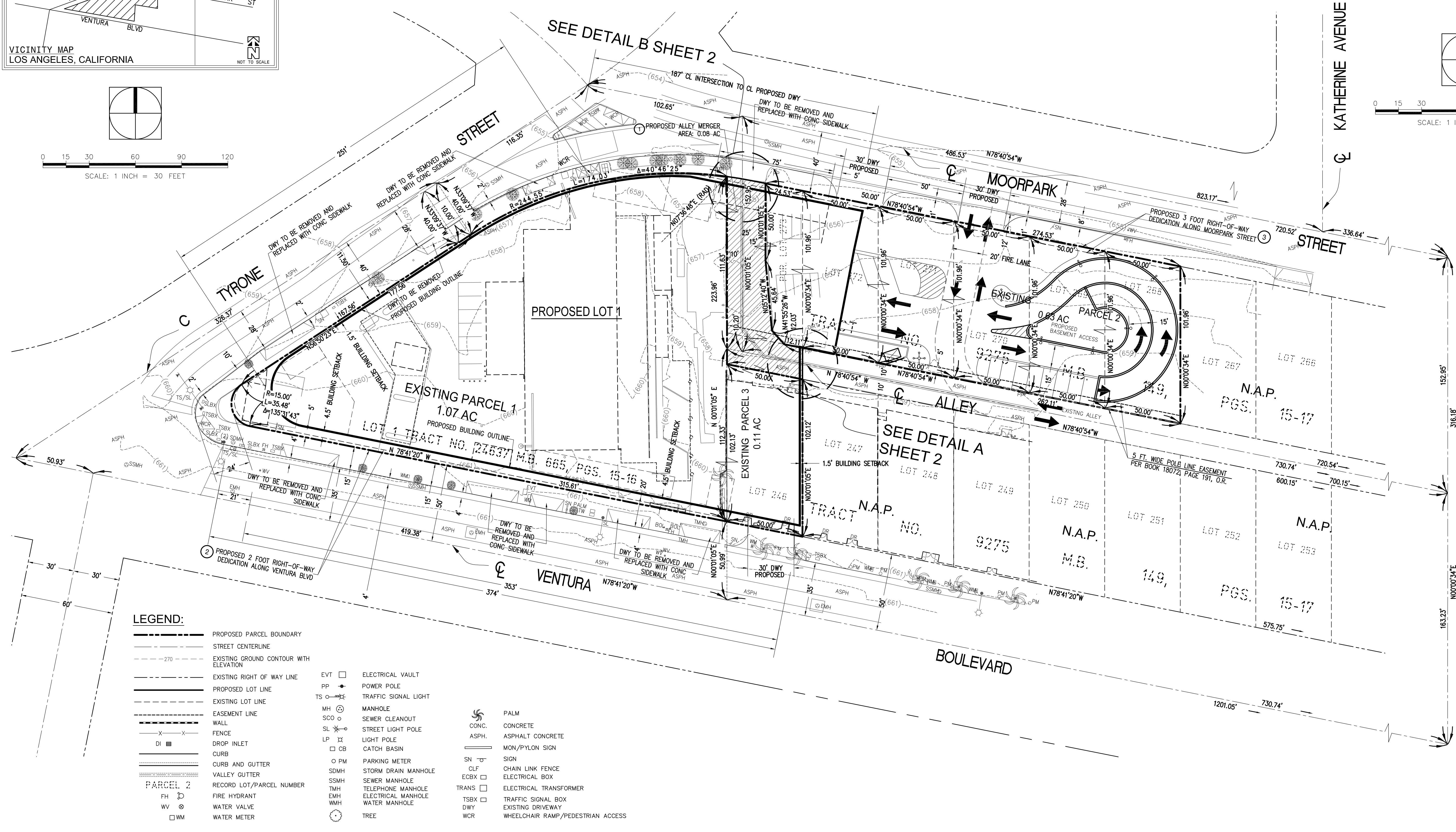
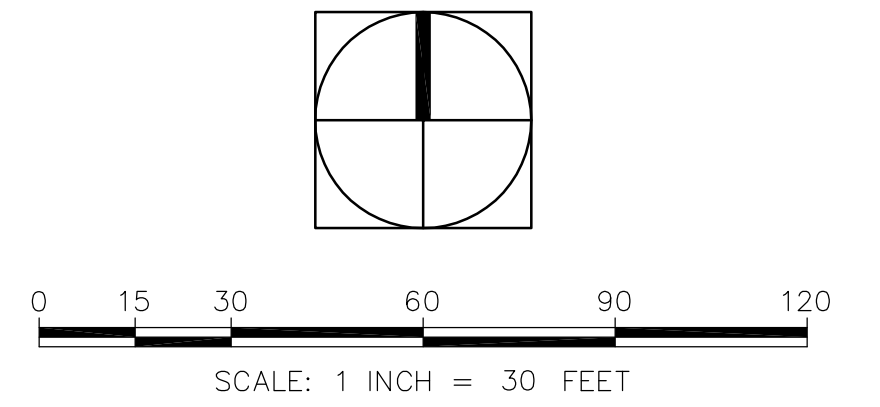

LEGEND:

— — — — —	PROPOSED PARCEL BOUNDARY	EVT □	ELECTRICAL VAULT
— — — — —	STREET CENTERLINE	PP ●	POWER POLE
- - - - -270-	EXISTING GROUND CONTOUR WITH ELEVATION	TS ○	TRAFFIC SIGNAL LIGHT
— — — — —	EXISTING RIGHT OF WAY LINE	MH ⊙	MANHOLE
— — — — —	PROPOSED LOT LINE	SCO ○	SEWER CLEANOUT
— — — — —	EXISTING LOT LINE	SL ⊙	STREET LIGHT POLE
— — — — —	EASEMENT LINE	LP ⊙	LIGHT POLE
— — — — —	WALL	□ CB	CATCH BASIN
— — — — —	FENCE	○ PM	PARKING METER
— — — — —	DROP INLET	○ SDMH	STORM DRAIN MANHOLE
— — — — —	CURB	SSMH	SEWER MANHOLE
— — — — —	CURB AND GUTTER	TMH	TELEPHONE MANHOLE
— — — — —	VALLEY GUTTER	EMH	ELECTRICAL MANHOLE
— — — — —	RECORD LOT/PARCEL NUMBER	WMH	WATER MANHOLE
— — — — —	PARCEL 2	○ T	TREE
FH ⊙	FIRE HYDRANT	CONC.	CONCRETE
WV ⊙	WATER VALVE	ASPH.	ASPHALT CONCRETE
WM ⊙	WATER METER	MON/PYLON SIGN	MON/PYLON SIGN
		SN ⊙	SIGN
		CLF	CHAIN LINK FENCE
		ECBX □	ELECTRICAL BOX
		TRANS □	ELECTRICAL TRANSFORMER
		TSBX □	TRAFFIC SIGNAL BOX
		DWY	EXISTING DRIVEWAY
		WCR	WHEELCHAIR RAMP/PEDESTRIAN ACCESS
			PALM

BASIS OF BEARINGS
THE BASIS OF BEARING FOR THIS SURVEY IS BASED ON THE CENTERLINE OF MOORPARK STREET, BEING NORTH 78°40'54" WEST, AS SHOWN ON TRACT MAP NO. 9275, ON FILE IN BOOK 665 PAGES 15 AND 126 OF MAPS, RECORDS OF LOS ANGELES, CALIFORNIA.

BENCH MARK
CITY OF LOS ANGELES BENCHMARK NO: 08-15936
SPIKE SET 1 FT. SOUTH OF THE SOUTH CURB LOCATED AT VENTURA BLVD., 18.6 FT. EAST OF THE BCR EAST OF BEVERLY GLEN BLVD. AT THE EAST END OF A CATCH BASIN.
ELEVATION: 660.610 FEET (NAVD 88 DATUM) (ADJ. 2000)

NO.	DATE	REVISION DESCRIPTION	APPROVED	DATE

CANYON CONSULTING
PLANNING • ENGINEERING • SURVEYING
11801 PIERCE ST., SUITE 200, RIVERSIDE, CA 92505

PETER E. WEILBACHER
09/30/16
DATE

VESTING TENTATIVE TRACT MAP NO. 74577
14311 VENTURA BOULEVARD
LOS ANGELES, CA
NORTHEAST CORNER OF TYRONE STREET AND VENTURA BOULEVARD

JOB NO. 15-058
DATE: SEPT 20, 2016
SHEET 1
OF 2 SHEETS

C:\Users\elw@h\Documents\Canyon Consulting\PROJECTS\115588 Ventura Blvd\Map\Tract No. 74577\15058-TM.dwg Oct 11, 2016 - 9:58am

VESTING TENTATIVE TRACT MAP NO. 74577

FOR LOT CONSOLIDATION AND ALLEY MERGER PURPOSES

IN THE CITY OF LOS ANGELES, COUNTY OF LOS ANGELES, STATE OF CALIFORNIA, BEING A MERGER OF LOT 1, OF TRACT NO. 24637, IN THE CITY OF LOS ANGELES, COUNTY OF LOS ANGELES, STATE OF CALIFORNIA, AS PER MAP RECORDED IN BOOK 665, PAGES 15 AND 16 OF MAPS, LOTS 246, AND LOTS 268 TO LOT 273, INCLUSIVE, AND THE MERGER OF A PORTION OF AN ALLEY AS SHOWN ON TRACT NO. 9275, IN THE CITY OF LOS ANGELES, COUNTY OF LOS ANGELES, STATE OF CALIFORNIA, AS PER MAP RECORDED IN BOOK 149, PAGES 15 TO 17 INCLUSIVE, OF MAPS, BOTH IN THE OFFICE OF THE COUNTY RECORDER OF SAID COUNTY.

LEGAL DESCRIPTION

VESTING TENTATIVE TRACT MAP NO. 74577, BEING A DIVISION OF THE FOLLOWING:

PARCEL 1:

LOT 1, OF TRACT NO. 24637, IN THE CITY OF LOS ANGELES, COUNTY OF LOS ANGELES, STATE OF CALIFORNIA, AS PER MAP RECORDED IN BOOK 665, PAGES 15 AND 16 OF MAPS, IN THE OFFICE OF THE COUNTY RECORDER OF SAID COUNTY.

PARCEL 2:

LOTS 268 TO 273 INCLUSIVE OF TRACT NO. 9275, IN THE CITY OF LOS ANGELES, COUNTY OF LOS ANGELES, STATE OF CALIFORNIA, AS PER MAP RECORDED IN BOOK 149, PAGES 15 TO 17 INCLUSIVE, OF MAPS, IN THE OFFICE OF THE COUNTY RECORDER OF SAID COUNTY.

EXCEPT FROM LOT 273 OF TRACT NO. 9275 THAT PORTION LYING WITHIN SAID TRACT NO. 24637.

PARCEL 3:

LOT 246 OF TRACT NO. 9275, IN THE CITY OF LOS ANGELES, COUNTY OF LOS ANGELES, STATE OF CALIFORNIA, AS PER MAP RECORDED IN BOOK 149, PAGES 15 TO 17, INCLUSIVE OF MAPS, IN THE OFFICE OF THE COUNTY RECORDER OF SAID COUNTY.

EXISTING EASEMENTS

- AN EASEMENT FOR POLES, CABLES, ANCHORS AND CONDUITS, AND RIGHTS INCIDENTAL THERETO AS SET FORTH IN A DOCUMENT RECORDED IN BOOK 18072, PAGE 191, OFFICIAL RECORDS. (AFFECTS THE SOUTHERLY 5 FEET OF LOTS 268 TO 273, 275 AND 276.)

NOTES

- VESTING TENTATIVE TRACT MAP IS FOR LOT CONSOLIDATION AND ALLEY MERGER PURPOSES ONLY.
- DATA SHOWN IS FROM A SURVEY IN 2015 AND AN UPDATED TITLE REPORT IN 2016.

GENERAL NOTES

- EXISTING LAND USE: GENERAL COMMERCIAL ZONE.
- EXISTING ZONING: THIS PROJECT IS DESIGNATED "C2-1VL", COMMERCIAL ZONE AND "[Q] P-1VL", AUTOMOBILE PARKING ZONE.
- SPECIFIC PLAN: VENTURA-CAHUENGA BLVD CORRIDOR.
- PROPOSED USE: GROCERY STORE WITH +/- 52,433 SQ. FT. FLOOR AREA.
- PROPOSED PARKING: 240 SPACES.
- PROPOSED METHOD OF SEWAGE:
- NO PROTECTED TREES ONSITE.
- PROPOSED BUILDING HEIGHT: 38 FEET 10 INCHES

LOT SIZE

EXISTING NUMBER OF PARCELS: 3
EXISTING PARCEL NET AREAS:

PARCEL 1 = 46,512 SQ. FEET (1.07 AC.)
APN: 2265-019-001
PARCEL 2 = 27,296 SQ. FEET (0.63 AC.)
APNS: 2265-019-022; -023; -024; -025; -026; -027
PARCEL 3 = 5,007 SQ. FEET (0.11 AC.)
APN: 2265-019-002
TOTAL NET AREA: = 78,815 SQ. FEET (1.81 AC.)

PROPOSED ALLEY TO BE MERGED

- AREA TO BE MERGED: 3,699 SQ. FT./0.08 ACRES

 ALLEY AREA TO BE MERGED

PROPOSED RIGHT-OF-WAY DEDICATION

- AREA TO BE DEDICATED: 693 SQ. FT./0.01 ACRES
- AREA TO BE DEDICATED: 930 SQ. FT./0.02 ACRES

PROPOSED NUMBER OF LOTS: 1
GROSS LOT AREA (INCLUDING ALLEY TO BE MERGED): : 82,514 SQ. FEET (1.89 AC)
NET LOT AREA: 80,891 SQ. FEET (1.86 AC)

GRADING PLAN NOTES

CUT: 32,100 CUBIC YARDS
FILL: 0 CUBIC YARDS
TOTAL EXPORT: 32,100 CUBIC YARDS

OWNER/APPLICANT

BRETT WOOD
14311 VENTURA DEVELOPMENT, LLC
1318 BROADWAY, 2ND FLOOR
SANTA MONICA, CA 90404

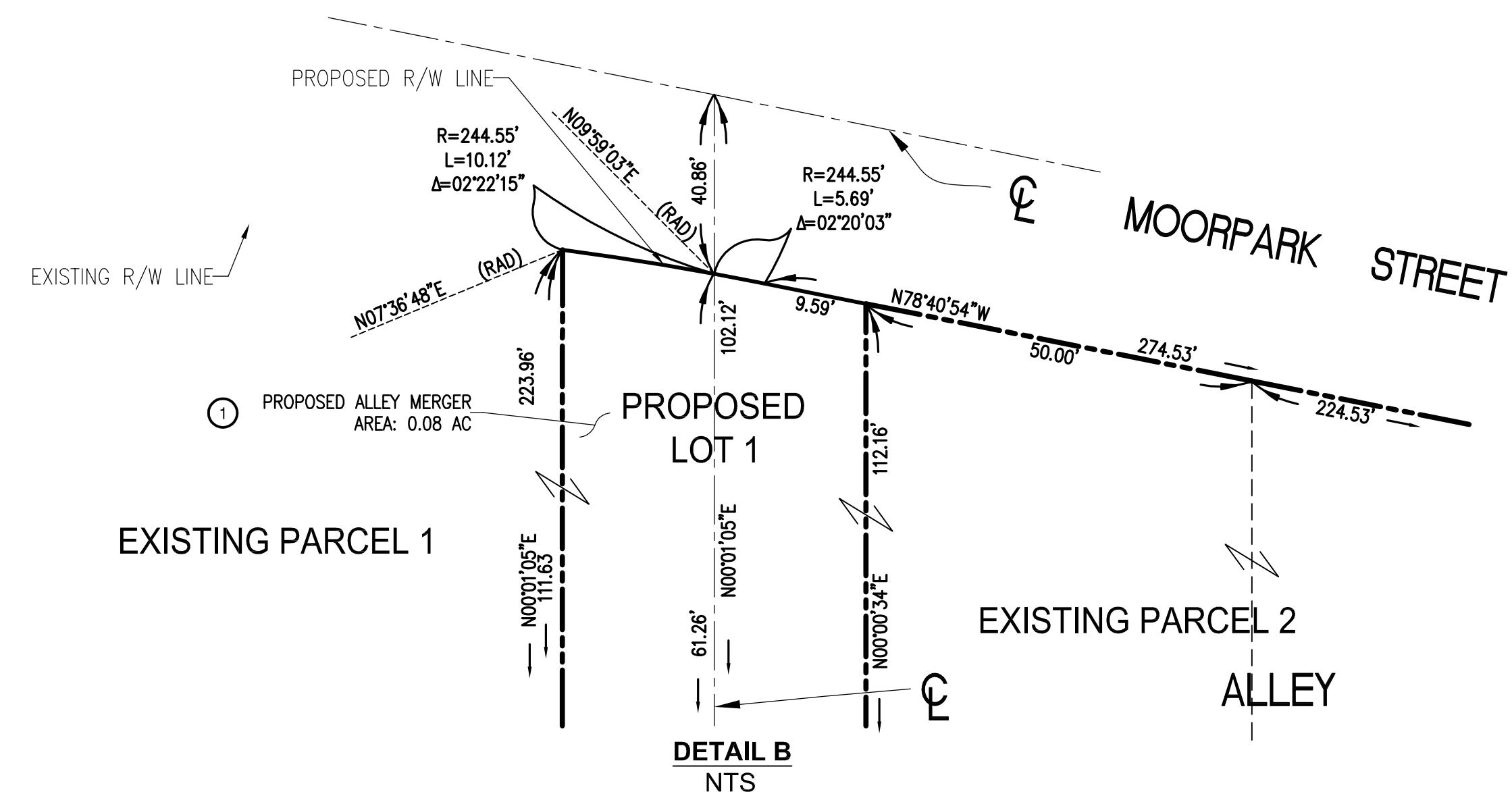
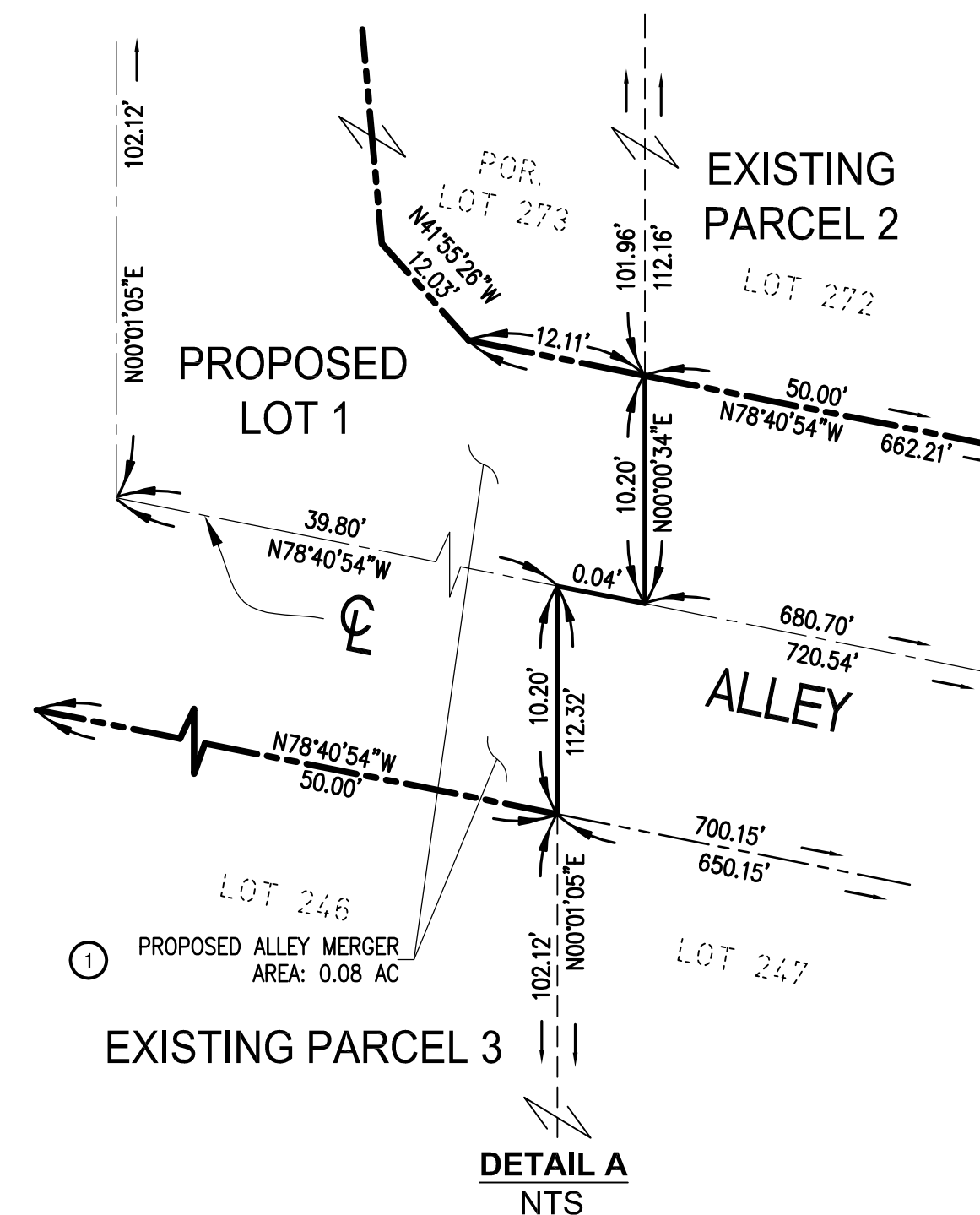

NO.	DATE	REVISION DESCRIPTION	APPROVED	DATE

BASIS OF BEARINGS	
THE BASIS OF BEARING FOR THIS SURVEY IS BASED ON THE CENTERLINE OF MOORPARK STREET, BEING NORTH 78°40'54" WEST, AS SHOWN ON TRACT MAP NO. 9275, ON FILE IN BOOK 665 PAGES 15 AND 126 OF MAPS, RECORDS OF LOS ANGELES, CALIFORNIA.	

BENCH MARK	
CITY OF LOS ANGELES BENCHMARK NO: 08-15936	
SPIKE SET 1 FT. SOUTH OF THE SOUTH CURB LOCATED AT VENTURA BLVD., 18.6 FT. EAST OF THE BCR EAST OF BEVERLY GLEN BLVD. AT THE EAST END OF A CATCH BASIN.	
ELEVATION: 660.610 FEET (NAVD 88 DATUM) (ADJ. 2000)	

CANYON CONSULTING
PLANNING • ENGINEERING • SURVEYING
11801 PIERCE ST., SUITE 200, RIVERSIDE, CA 92505

PETER E. WEILBACHER
09/30/16
DATE

VESTING TENTATIVE TRACT MAP NO. 74577
14311 VENTURA BOULEVARD
LOS ANGELES, CA
NORTHEAST CORNER OF TYRONE STREET AND VENTURA BOULEVARD

JOB NO.	15-058
DATE:	SEPT 20, 2016
SHEET	2
OF 2 SHEETS	

C:\Users\helenh\OneDrive - Canyon Consulting\PROJ\ECTS (115888 Ventura Blvd\dwg)\Tentative Tract Map No. 74577\15058-TM.dwg Oct 11, 2016 - 9:56am